

Ultimate Bath/Dryer Vent™

For Use With Shingle Roof Coverings

**LIFETIME TOOL®
& BUILDING
PRODUCTS LLC**

Product Description

The Ultimate Bath/Dryer Vent™ (BDV), an exhaust vent for shingled roof covering materials, is a through-the-roof high-performance exhaust vent assembly, designed and engineered to sustainably flash and seal the roof penetration to provide a long-term watertight installation.

Created as a durable assembly for steep slope roof use, the patented design incorporates industry leading penetration sealing methods and field adaptable connection means for either a bathroom vent exhaust duct or a clothes dryer exhaust duct.

With an aerodynamic exterior styling and featuring a lightweight coated aluminum damper, the assembly has been tested to withstand over 110 MPH wind driven rain without failure or leakage.

The engineered assembly incorporates resilient features for noise suppression providing industry leading quiet damper operation. The streamlined design for exhaust flow through the assembly ensures the lowest pressure drop found on any roof mounted exhaust vent assembly, and the lowest cracking pressure of any damper system on the market, resulting in the highest performance for a bathroom vent or clothes dryer exhaust. The assembly is constructed with a field removable cover for routine top-down cleaning and maintenance of the duct system.

The BDV can be used with any steep slope shingle style roof covering including asphalt shingles, slate, cement tile, cedar shakes, and more. The flashing plate and cover are constructed from Kynar® coated 24-gauge G-60 galvanized steel sheet which is exceptionally well suited for use in all but the most corrosive high chloride environments.

Instructions & Recommendations for Use

The BDV is packaged in a protective carton which is imprinted with bilingual instructions illustrating proper installation on the roof. Included in the carton is a 4" galvanized duct drop connector, a polypropylene 3" to 4" duct adapter, and a snap-in bird and vermin screen (for non-clothes dryer exhaust applications only).

It is recommended that the BDV be delivered to the vent penetration on the roof in the original protective carton. In this manner the installer will have everything required on the roof and will have the carton with bilingual instructions at the installation site for reference.



Prior to installation, the 4" duct drop connector must be field assembled to the main vent assembly as shown on the carton instructions and illustrations. This is a simple operation, just align and press to snap into place, then check to ensure a proper connection is achieved. Duct connections can be made from the roof if the duct can be accessed through the roof during installation, if not then attic space access by the installer will be required.

Once duct connections are either completed or are considered for later connection within the attic space, install the BDV exhaust vent over underlayment on the substrate and layered into the shingle courses as appropriate for the vent roof penetration location to ensure proper shingle overlap for a watertight rain shedding installation. Anchor the flashing plate to the substrate through the nailing slots provided for optimum load resistance and long-term performance.

The use of mastics or sealants is not required, however, the installer can use sealants and other miscellaneous items as required by the shingle manufacturer during installation.

Additional information, including instructional videos of installation techniques can be found on the Lifetime Tool® website at www.lifetimetool.com

Benefits of using the Ultimate Bath/Dryer Vent™

The engineered Ultimate Bath/Dryer Vent™ assembly utilized materials known for long-term outdoor exposure, including:



- Kynar® coated 24-gauge G-60 galvanized steel sheet for the flashing plate and for the cladding on the removable cover sub-assembly
- Exterior grade heavy wall injection molded ASA is utilized for the structure of the vent housing and removable cover
- Compression molded high consistency EPDM elastomer used to provide a watertight seal. Assembled and sealed using a proprietary inseparable crimp method over a high consistency compression molded elastomer for long-term performance.
- Extreme weatherable polymer coated aluminum is utilized for the thin wall deep formed damper which is inseparably affixed to a 303 stainless steel axle to provide years of non-corrosive service

The patented Ultimate Bath/Dryer Vent™ features a lightweight damper system, including noise suppression components for long-term quiet operation. The deep formed design of the damper component assists in shaping the exhaust flow stream and allows the use of thinner and lighter materials enabling the lowest opening pressure differentials in the industry and providing one of the lowest pressure drops through the device for any roof mounted exhaust vent. All resulting in improved long-term performance of a bathroom vent fan or clothes dryer exhaust.

The flashing plate is produced with generous side and top margins to allow substantial overlap with the shingled roof covering materials, providing an excellent rain shedding finished installation.

Created with an aerodynamic shape to resist wind uplift during high wind events, the BDV is an aesthetically pleasing part of the roofing system, not a box on the roof. The field removable/replaceable cover assembly provides the ability for routine periodic top-down maintenance and clean out of the connected exhaust duct system. This feature is found on no other commercially available exhaust vent assembly and is especially important for clothes dryer exhaust duct connections.

A high-performance stainless-steel bird and vermin screen is included for use in **NON-CLOTHES DRYER** exhaust duct connections **ONLY**.

All components are made, assembled, and packaged in the U.S.A. Warrantied for the life of the roof covering materials that it is installed with. A truly sustainable roof component built to last and perform on the roof.

Specific Data - Materials of Construction:

- **Flashing Plate** – Deep drawn and stamped Kynar® coated 24-gauge G-60 galvanized steel sheet with a classic dark bronze finish. Meets or exceeds ASTM A635-09 standards, providing superior corrosion resistance in all outdoor environments except coastal and beach front homes and buildings.
- **Internal Structure & Cover Body** – Injected molded heavy wall ASA polymeric compound known for excellent weatherability and dimensional stability
- **Damper**– Formed from a precoated aircraft grade aluminum alloy and is inseparably affixed to a 303 stainless steel axle.
- **Crimped Watertight Seal Component**– Compression molded from a proprietary grade of EPDM thermosetting elastomer, as are the noise suppression components utilized to prevent damper noise during operation and high wind events.
- **Cover**– Aerodynamic and deep drawn from a Kynar® coated 24-gauge G-60 galvanized steel sheet with a classic dark bronze finish. This drawn cover element is inseparably affixed to the injection molded ASA cover body.
- **Cover Screw Fasteners & Threaded Nuts**– Allow removal of the cover for cleaning and maintenance, are manufactured from marine grade 316L stainless steel and are finished with a black oxide coating for a lifetime of use on the roof.

Availability:

The Kynar coated 24-gauge G-60 galvanized steel Ultimate Bath/Dryer Vent™ is available for use with shingled roof covering materials, as shown in the dimensions and sizing drawings on the next page.

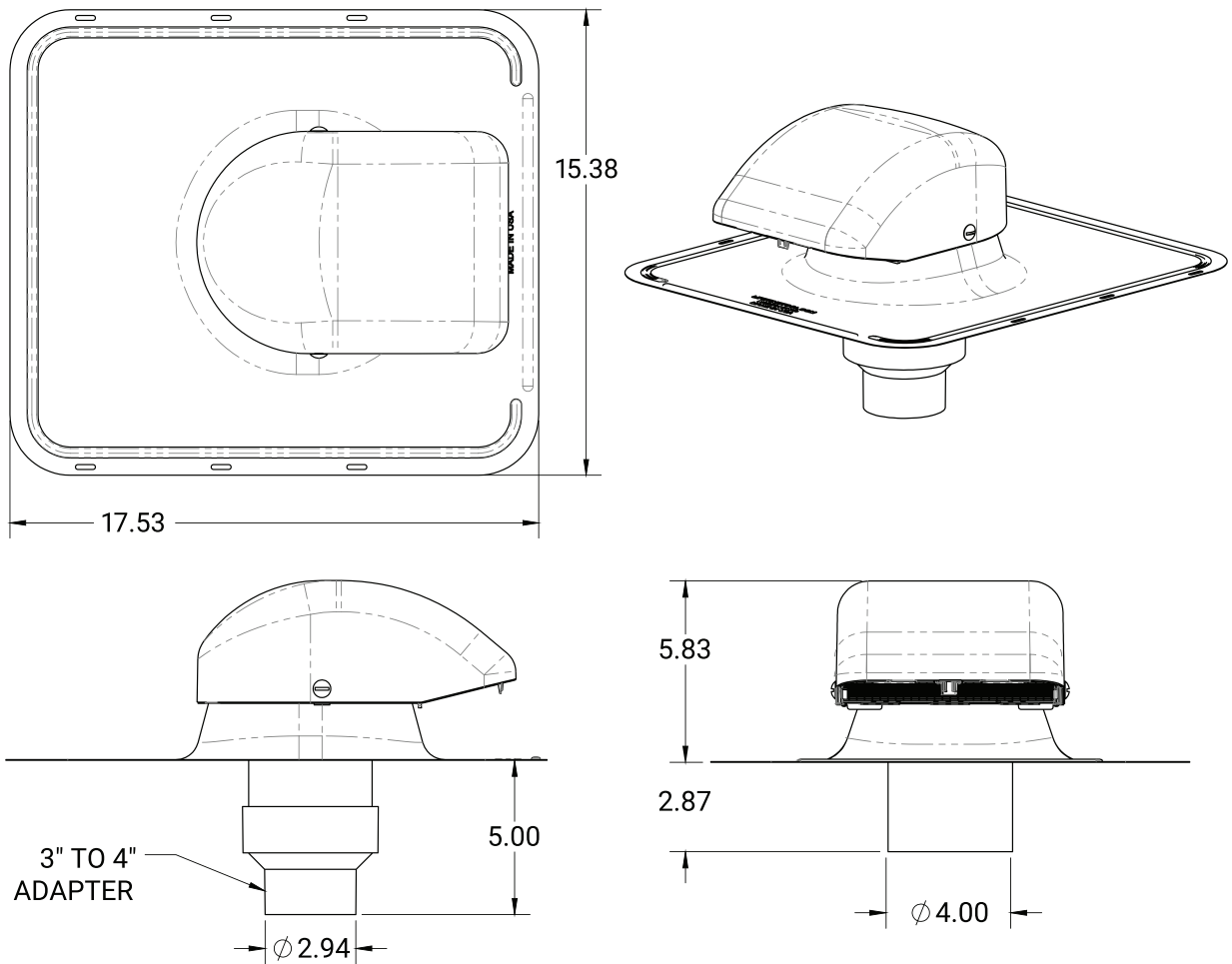

The Ultimate Bath/Dryer Vent™ For Shingled Roofs Meets Each Of The Testing Criteria Below:

Applicable Testing:

- ASTM E 166-18 Wind and Wind Driven Rain Performance Test (exceeded 110 MPH)
- T151-18 Air Flow Test (Pressure drop through various vents)
- T133-19 Air Flow Performance Test
- Florida TAS 100-95 Test procedure for wind and wind driven rain resistance (110+ MPH)

Notice:

All parts are manufactured and assembled in the U.S.A.
 Protected by U.S. Patents 10,927,550 and D934,409
 Florida Product Approval No. FL 31164
 Lifetime Tool® is registered by and the property of Lifetime Tool and Building Products, LLC no unauthorized use is permitted.
 CAGE Code No. 94YWS